

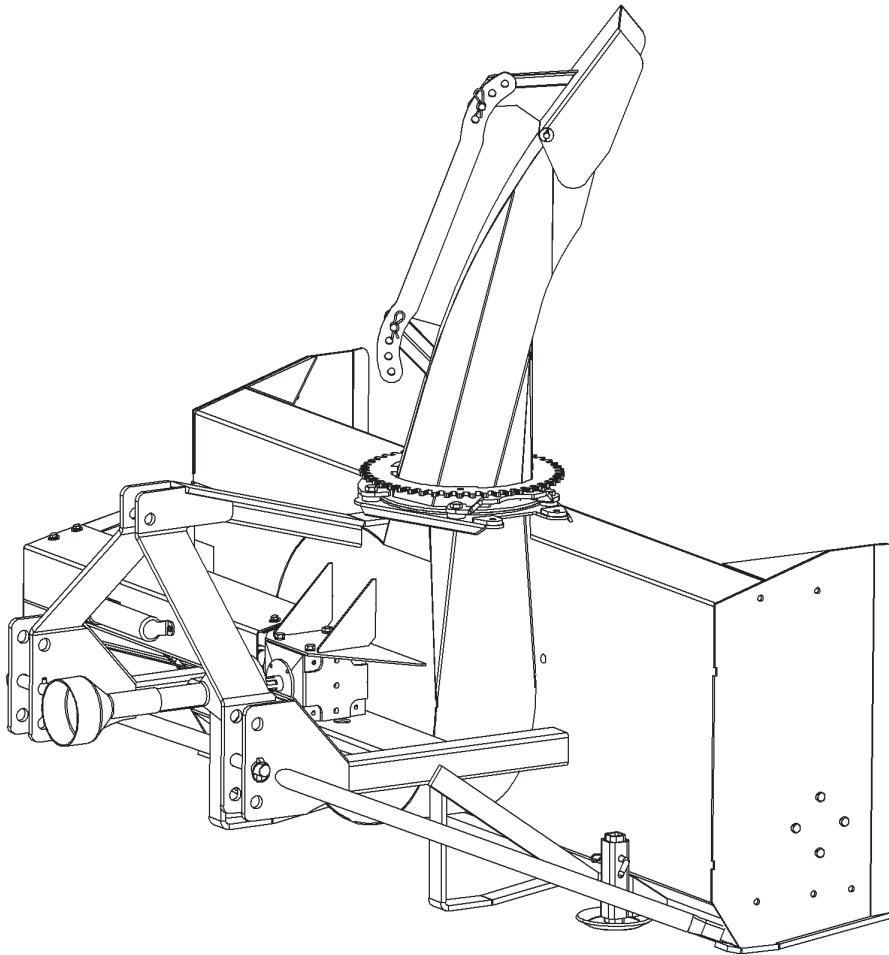

87-97 Meteor Snowblower Operator's / Parts Manual



M K Martin Enterprise Inc
3950 Steffler Rd Elmira On Ca N3B 2Z3

Tel: 519-664-2752
Toll Free 1-855-664-2752
Fax: 519-664-3695
e-mail: sales@mkmartin.ca
www.mkmartin.ca

Intentionally Blank

Table Of Content

- Registration
- Warranty
- Safety
- Decal Location
- Assembly Instructions
- Set-up
- Operation Instructions
- Installing Manual Chute Rotator
- Installing Hydraulic Chute Rotator
- Chute Stop
- Parts
- Manual Chute Rotator Parts
- Hydraulic Chute Rotator Parts
- Gearbox Parts
- PTO Parts
- PTO Instructions
- Bolt Torque Chart
- Maintenance

Warranty Regeneration

Please Cut and Return to M K Martin Enterprise Inc

Fold And Tape here Do not tape all edges or use staples

Fold Here

**Postage
Stamp**

**M K Martin Enterprise Inc
3950 Steffler Rd
Elmira ON CA N3B 2Z3**

M K Martin Enterprise Inc
3950 Steffler Rd
Elmira On Ca N3B 2Z3

Purchaser's warranty protection equipment is valid only when this completed form or a copy of this form is on file at M K Martin Enterprise Inc. By filling out this form the purchaser has acknowledged delivery of equipment and owner's / operator's manual and has accepted the condition of the equipment.

Date of delivery to purchaser -----

Type of Equipment -----

Model # ----- **Serial #** -----

Retailer's Signature Indicates

- *Equipment was properly assembled as directed by manufacturer*
- *Equipment was tested for functionality and operates properly*
- *Purchaser was instructed in safe and proper operating procedures*
- *Warranty was explained to purchaser*
- *Purchaser was give the operators manual*

Retailer

Signature -----

Company -----

Address -----

Purchaser's signature indicates

- *Acceptance of equipment fully assembled*
- *Received operator's manual*
- *Clearly understands conditions of warranty*
- *Received instructions of safe and proper operation of equipment*

Purchaser

Signature -----

Company -----

Mailing address -----

City ----- **Prov/State** ----- **Postal Code/Zip** -----

Available phone number -----

Warranty is valid only when it has been received by manufacturer at address

Warranty and Limitations of Liability

All equipment is sold subject to mutual agreement that it is warranted at M K Martin Inc. (Hereafter called the company). to be free of any defects of material and workmanship. The company shall not be liable for special, indirect consequential damage of any kind under this contract or otherwise. The company's liability shall be limited exclusively to replacement or repair without charge at it's factory or elsewhere, at it's discretion, any materials or defects, which become apparent within one year form the date of purchase. In no event shall M K Martin Enterprise Inc. be liable special, direct, or incidental or consequential damages of any kind. The purchaser by acceptance of the equipment will assume all liability for ant damage which may result from use or misuse by the employees or others. The purchaser shall maintain and service the equipment as recommended in the Operator's Manual.

This warranty does not cover **Rental/Commercial or Rental** use of the equipment. This equipment is rated as agricultural.

For **Rental/Commercial or Industrial** use, Warranty is for defective material and workmanship for a period of 90 days from the date of purchase.

Warranty is null and void unless the Warranty Registration from has beens completed and on file at

M K Martin Enterprise Inc
3950 Steffler Rd
Elmira On Ca N3B 2Z3

For your Record

Purchase Date _____

Model # _____

Serial # _____

Please contact your retailer

Manufactured by
M K Martin Enterprise Inc
3950 Steffler Rd
Elmira On Ca N3B 2Z3
Tel: (519)-664-2752
(855)-664-2752
Fax: (519)-664-3695
E-mail: sales@mkmartin.ca

www.mkmartin.ca

Safety

Take Note! This safety symbol is found throughout this manual to call your attention to instructions involving yourself and others working around the machine.

- **Failure to follow these instructions can result in injury or death!**



This symbol means

- **Attention!**
- **Become Alert!**
- **Your Safety is involved!**

Signal words are used in this manual.

Caution: Indicate a potential hazardous situation that may result in injury.

Warning: Indicates a hazard situation that could be result in serious injury or death.

Danger: Indicates a hazardous situation that needs to be avoided. It is you the operator that needs to be aware of these dangers.

If you have any questions not answered in this manual please contact you dealer or

M K Martin Enterprise Inc
3950 Steffler Rd
Elmira On Ca N3B 2Z3

Tel: 519-664-2752
1-855-664-2752
Fax: 519-664-3695
e-mail sales@mkmartin.ca

www.mkmartin.ca



Safety -- It's in your interest.



Safety Guidelines

Safety of operation is one of our main concerns, however it is up to the operator to practice caution. To avoid personal injury, study the following precautions and insist that those working with you follow them.

The Meteor Snowblower has only 2 shields, one shield is the PTO drive shield and the other is a shield for the power hood turner if used. **Do not use the blower with the auger drive cover removed as this is part of the blower frame.**

Replace any decals that may be missing or not readable. Location of decals are indicated elsewhere in this manual.

Do not use the machine while under the influence of drugs or alcohol.

Review the safety instructions with all users annually.

This equipment should not be operated by children: or those unfamiliar with the operation of the Meteor Blower. **Do not allow persons to operate this machine until they have read this manual and/or were instructed by a qualified person,**

Do not use this machine to push snow as this can result in the auger to be broken or bent.



Please be careful with the extra weight on the back of the tractor. It may be necessary to add weights on the front of the tractor to keep it balanced properly.



When changing shear-bolts or removing ice or snow from the machine **Please stop the engine and remove the key on the tractor!** This will reduce the possibility of the blower to be started and causing personal injury.

Sign Off Form

M. K. Martin Enterprise Inc. follows the general Safety Standards specified by the American Society of Agricultural Engineers (ASAE) and the Occupational Health and Safety Administration (OSHA). Anyone who will be operating and/or maintaining the Cutter must read and clearly understand ALL Safety Operating and Maintenance presented in his manual. Do not operate or allow anyone else to operate this equipment until such information has been reviewed. annually review this information before the season start-up. Make these reviews of SAFETY and OPERATION annually as a standard practice for all your equipment. We feel that an untrained operator is unqualified to operate this machine. A sign-off sheet is provided for your record keeping to show that all personnel who will be working with the equipment have read and understood the information in the operator's manual and have been instructed in the operation of the equipment.

Date	Employees Signiture	Employers Signiture

Meteor Snowblower Decal Location

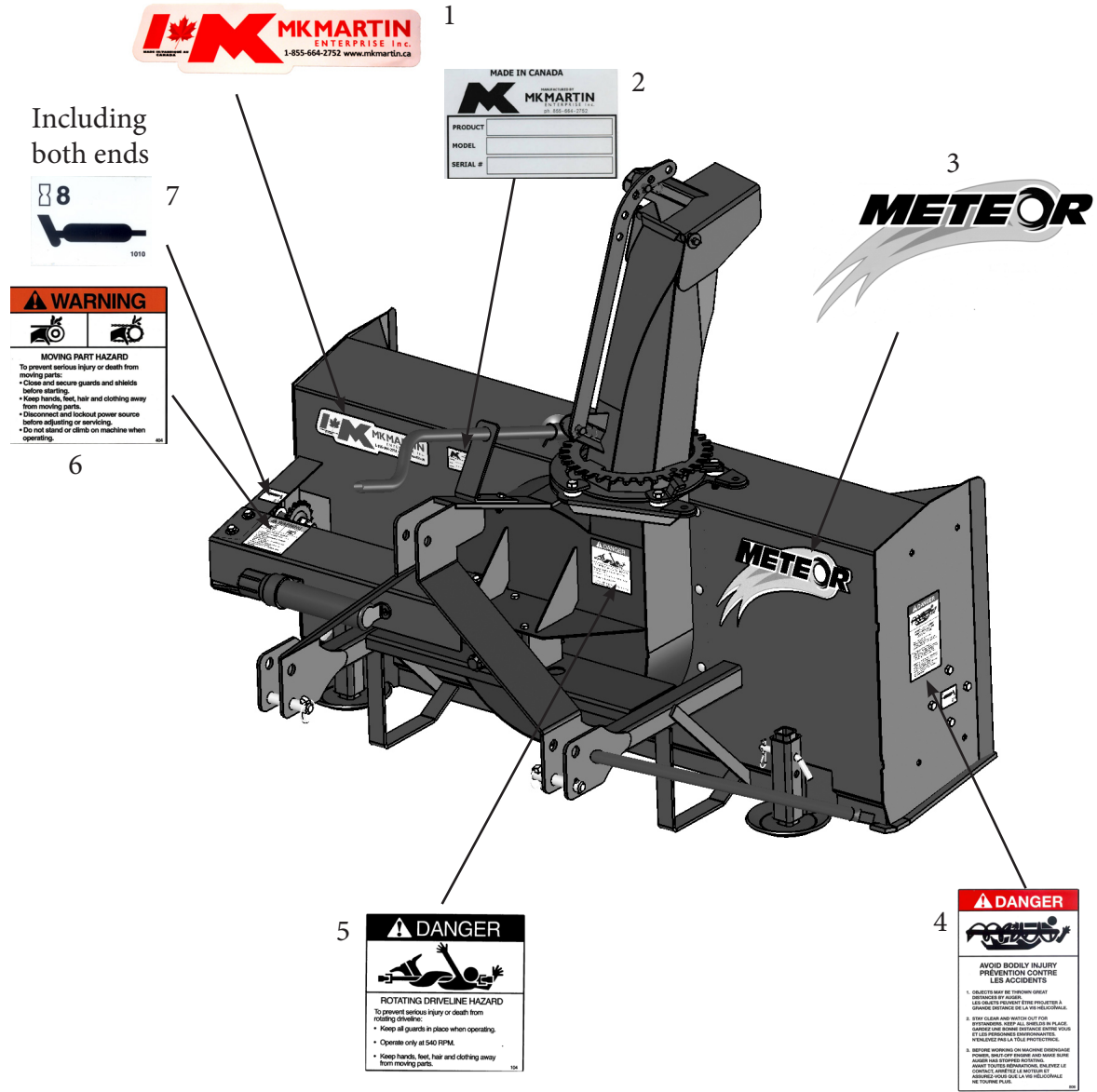

Both ends

Item #	Part #	Description	Qty
1	decalMKlogomadeincanada	M K Martin Logo	1
2	No Replacement	Serial Plate	1
3	decalmeteorlarge2012	Meteor Logo	1
4	101	Danger Decal	2
5	104	Danger Decal	2
6	404	Warning	1
7	decal1010	Grease	3

75-108 Meteor Snowblower Assembly Instructions

Parts for Assembly

- 2 pc Hood Bearing
- 4 pc 5/8" Wavewasher (*thin*)
- 2 pc 5/8x2 UNF bolts
- 2 pc 5/8" NUF Locknut
- 1 pc 2 Hole Chute Clamp
- 1 page Assembly Instructions

Upon Receiving the Meteor Snowblower

The bolwers are shipped in a packaged state

These Snowblowers are shipped without hood turner device

Carefully remove the chute and PTO shaft from the area of the snowblower auger and set them aside.

Locate the bag or package of small components.

Remove the ties that hold the Plastic Ring on the blower and place base of the chute on top of the plastic ring. (Note: PLastic Ring can be lightly coated with grease at this time).

Take two 5/8 bolts and drop them through the holes in the chute clamp, turn th eclamp upside down while holding the bolts in the holes. Place a 5/8 Wavewasher on the bolt, then a 5/8 Bearing, finish with another 5/8 Wavewasher. Turn the clamp rightside up with the washers and bearings on the bolts. Carefully insert the bolts into the chute base and secure with the locknuts.

Install the PTO with the shearbolt yoke at the gearbox. *This will provide you with more space when changing shearbolts.*

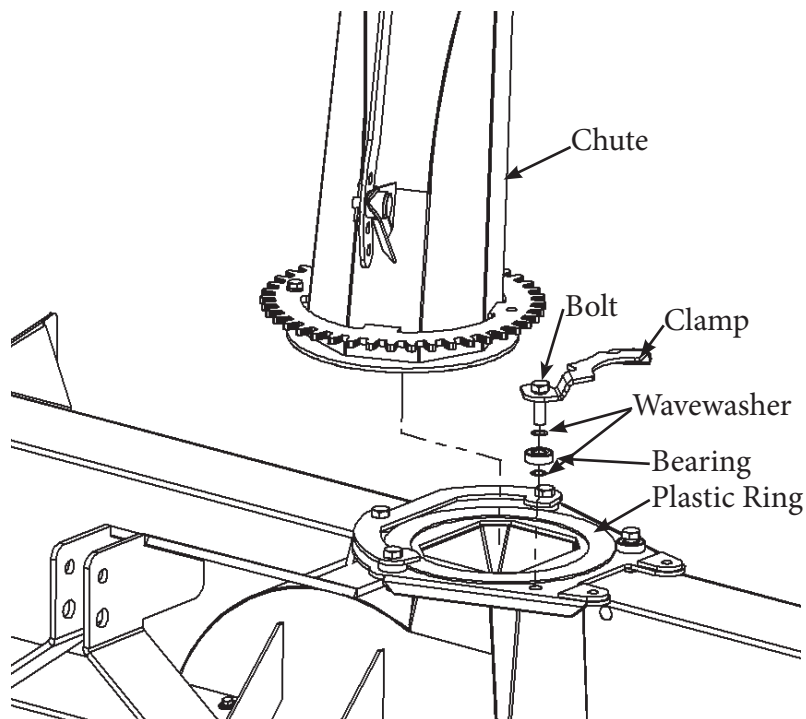

87-97 Meteor® Snowblower

This Blower is ideal for tractors 60-75 HP Cat #2 3PH.

Attaching up the Meteor® Blower for the first time.

Set the blower on a level surface and back the tractor up to it. Place the lower 3PH arms of the tractor between the lower hitch plates on the blower and insert the hitch pins that came with the blower, secure these with the Lynch Pins. Next swing the top link into place and adjust the length so the top link pin can be inserted. You will have to supply the top link pin. With the top link set at this length the blower will be flat or parallel to the ground.

Do not fasten the PTO shaft to the tractor.

1. Slowly lift the blower until the gearbox shaft is at the same height as the PTO output on the tractor.
2. Push (or collapse the telescopic part of the PTO completely). If you cannot collapse it far enough to get it on the tractor then it has to be shortened.
3. Measure the amount that the shaft is too long. Remove it from the blower and pull it apart.
4. Take a hacksaw and cut ½ of the measurement from each end, cut both the plastic tube and the metal core.
5. Use a file to remove the burrs from the cut parts, wipe any filings from the surfaces and slide the shaft together to be sure that it slides freely.
6. Make sure the plastic shield is free to rotate on the shaft before installing on the machine.
7. Reinstall the PTO on the blower and fasten it to the tractor pushing the spring-loaded pin in and sliding the yoke onto the tractor spline until the pin snaps into place.
8. Next lift the 3PH arms to the highest point, determine the overlap on the PTO shaft. It should be at least 3” if it is too short then the PTO will jam rather than collapse. This will put severe strain on the shaft and gearbox.



9. It may come apart and this will allow a spinning PTO to become an uncontrolled weapon and could severely injure or kill someone!
10. After it has been determined that the PTO is OK and will not jam or come apart, make sure any bystanders are well away from the machine.
11. Lower the blower to ground level, engage the PTO and slowly start the blower. Make sure that everything is turning freely.
12. Slowly increase the speed until you have reached 540 RPM on the PTO. This is the speed that this blower was designed for. If it turns faster the fan could be going dangerously fast. If it turns slower it will not perform very well as the snow will not get blown very far.

Snowblower performance will vary greatly due to ambient temperature and type of snow.

Operating the Meteor® Snowblower

This blower is on the back of the tractor facing toward the rear. While blowing snow the tractor has to be backed into the snow.



Stay in the seat of the tractor all the time that the blower is running.



Make sure the area is clear of people while blowing snow.



Do not direct discharged snow toward people, cars or buildings as stones or bits of ice can go a long distance.

When you get to the place that you want to clear of the snow, lower the blower to the ground and turn the chute to discharge the snow in the direction you want the snow to go. Engage the PTO and slowly bring the blower up to operating speed. After the blower is running use reverse gear and start backing up. The chute can be rotated from the tractor seat while blowing snow.

If your drive is paved then you may need to lengthen the top 3PH link to tilt the blower ahead so it will scrape the hard surface better.

If your drive is gravel then you may want to shorten the top 3PH link to tilt the blower back so it will not dig into the loose gravel. In colder climates where the bare ground is frozen during most of the winter the blower can be adjusted to scrape the snow off the frozen drive after freeze-up.

In areas where the gravel is not frozen most of the time we have optional skid shoes available to raise the blower a few inches above the gravel.



This blower is designed to blow snow, but will blow loose gravel if care is not taken.



After the job is finished: **Disengage the PTO to stop the blower** before driving away or getting off the tractor.

The auger is protected with a safety shear bolt that will shear off if the auger becomes jammed.

The fan is also protected with a shear bolt in the PTO shaft universal joint if the fan becomes jammed.



When replacing the shear bolts STOP the engine before attempting to replace them!

There is a hydraulic hood turner available that couples into the tractor hydraulic remotes if your tractor is so equipped. This will allow you to rotate the hood without reaching back to the blower especially if you have a cab on your tractor.

75-108 Installing the Hand Crank

The Crank package consists of

- Tail Bracket --- (1)
- Upper Bracket- (2)
- Worm Gear ---- (3)
- Crank ----- (4)
- Spring Pin ----- (5)
- Set Screws ----- (6)
- Bolts ----- (7)

Bolts
2 pc 3/8x1
2pc 3/8 Lockwasher
2pc 5/8 x 2 1/4 UNF Bolt to replace 5/8 x 2

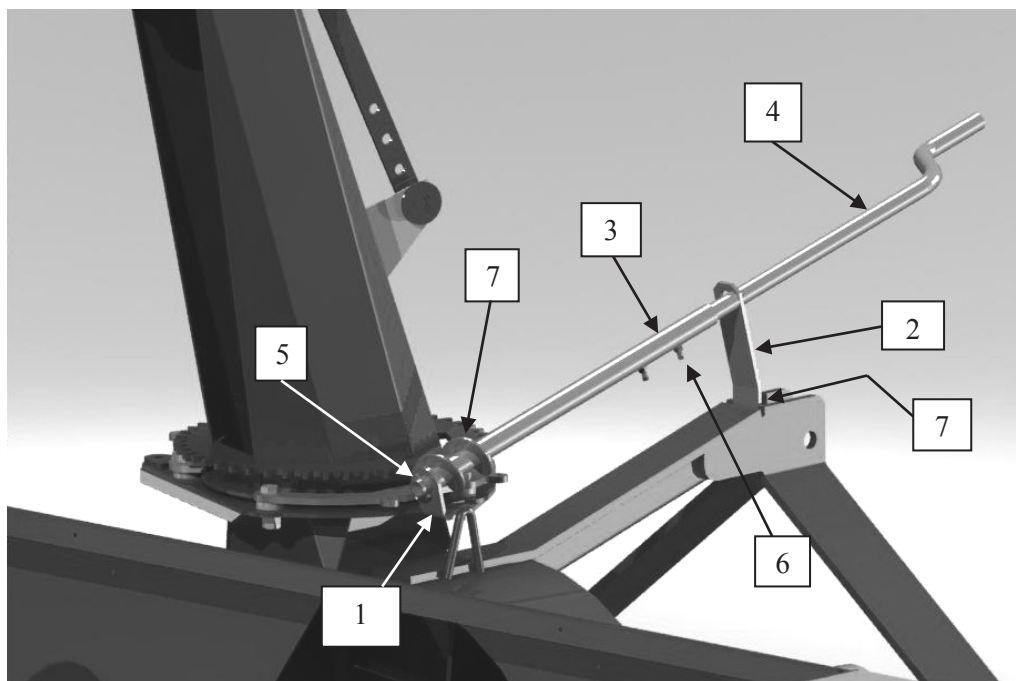

First remove the 2 nuts and bolts (as indicated), and insert the Crank Tail bracket[1] and reinstall with 5/8 x 2 1/4 bolts (supplied) and Locknuts.

Insert the bottom end of the worm gear [3] into the Tail Bracket, slide the top bracket [2] into place and secure with bolts [7]. Install spring pin [5]

Slide Crank [4] into tube as shown and secure with the Set Screws [6],



Please note! When the blower is raised, the Crank will be closer to the tractor and could damage the cab or cause injury to the operator!

Motor Hydraulic Rotator Installation

The Hydraulic Chute Rotator uses a hydraulic motor, controlled by the tractor hydraulics to rotate the chute. The kit includes a safety shield, 2 pc 1/2-20 UNF bolts, hydraulic fittings, hoses and tractor couplings. When installing the hydraulic elbows, turn them in “**no more than 4 rounds**” then tighten the jam-nut to secure the elbow in the direction that you want the hoses to go *as shown*.

The relief valves are factory preset at 900 PSI.

Route the hoses and tie them to the top “A” frame support, away from moving parts, Ensure that the hoses do not get too tight or rub on the frame when the blower is raised or lowered.

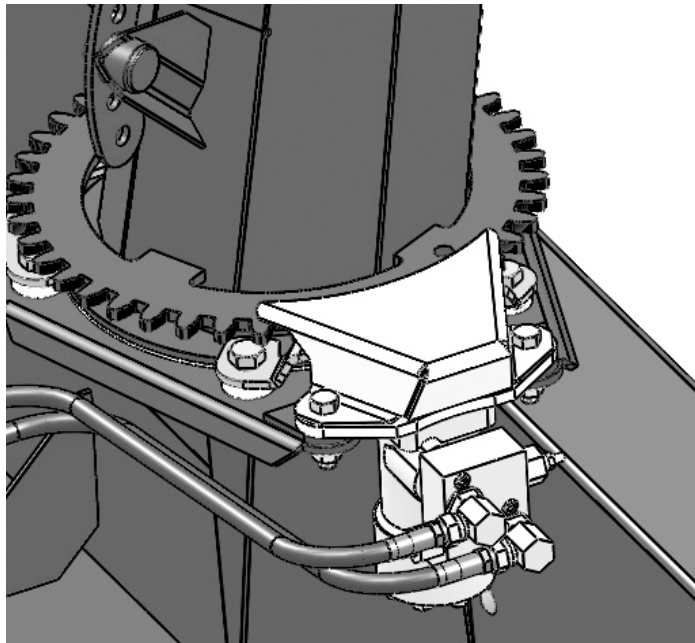

First set the motor with the bracket on top of the Chute Plate and then place the shield on top of the motor bracket and secure with 1/2-20 UNF bolts

Please ensure that the gear does not jam or bind during the rotation of the chute. The bolt holes are slightly oversize, allowing you to adjust the clearance somewhat. You should be able to move the chute back and forth slightly.

Meteor Snowblower

Installing Hydraulic Chute Rotator Safety Shield with Hose Guide

The Meteor Hydraulic Chute Rotator has rods that act as guides to guide the Deflector Hydraulic Hose (if used) to the outside of the shield.

All Shields are manufactured with the Rods straight.

They may need to be bent in or out for smaller or larger blowers.

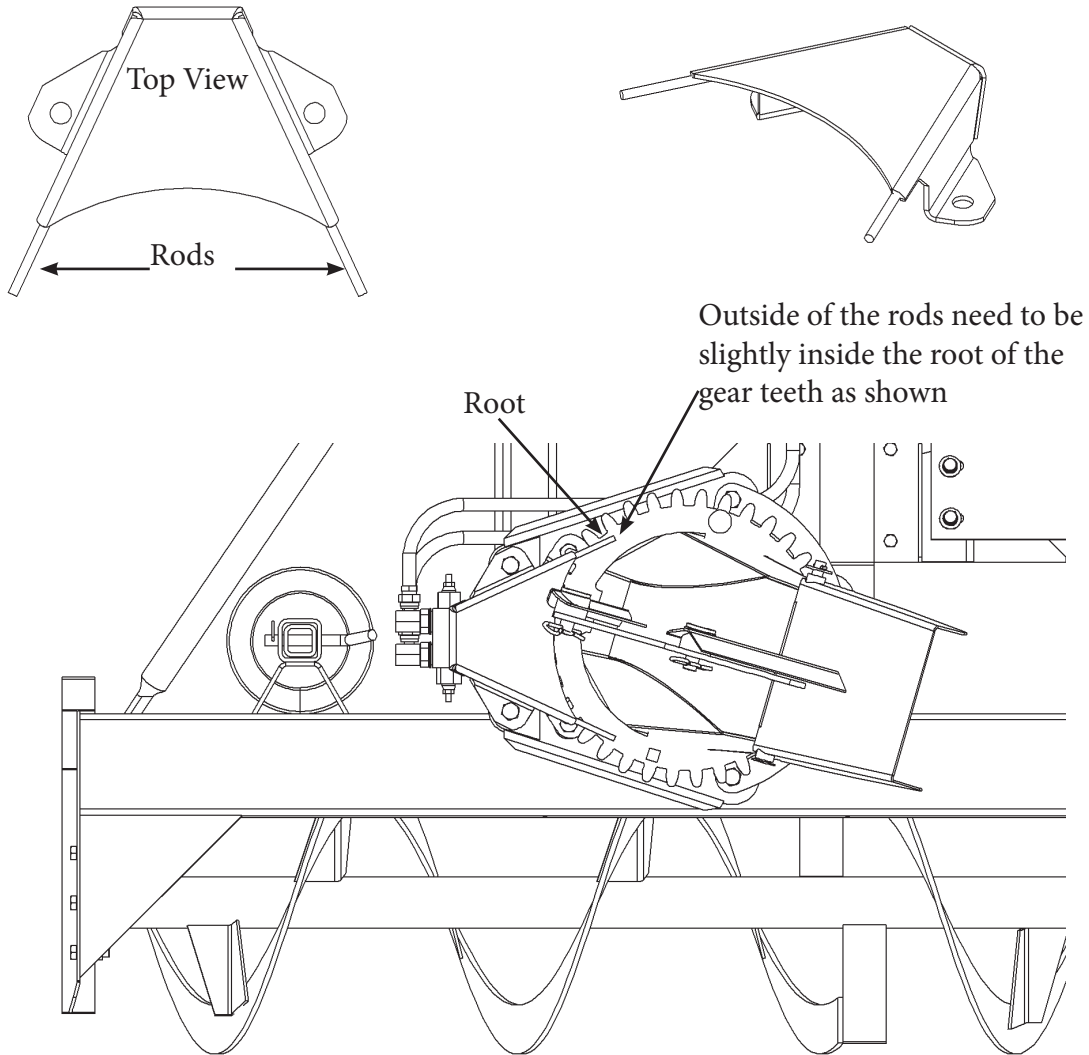

To bend the rod, you can use a short piece of 3/8 pipe for a lever, or an adjustable wrench to bend the rod.

Do not use a hammer as it has less control of the bend.

Keep the height of the rod the same, only bend it in or out.

After installation carefully rotate the chute to ensure that there is no interference or binding.

For Smaller blowers rods are bent in
as shown

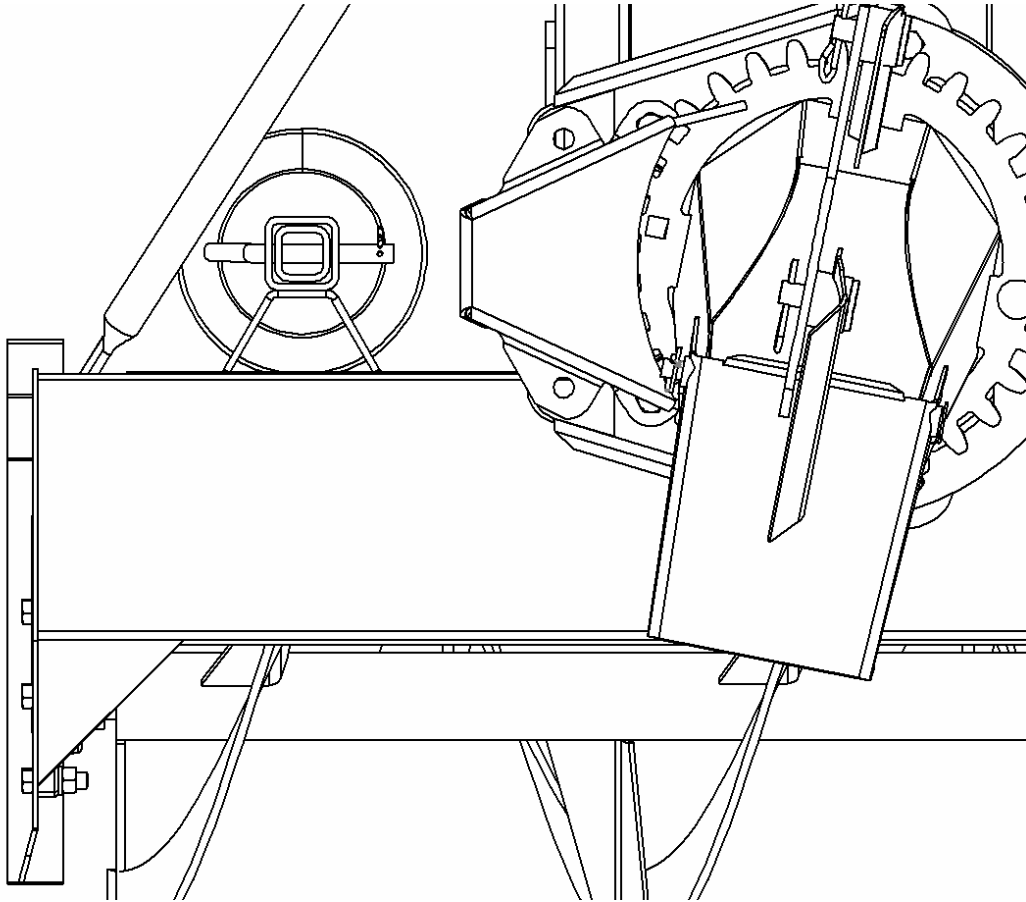

For Larger Blowers rods are Bent out
as shown

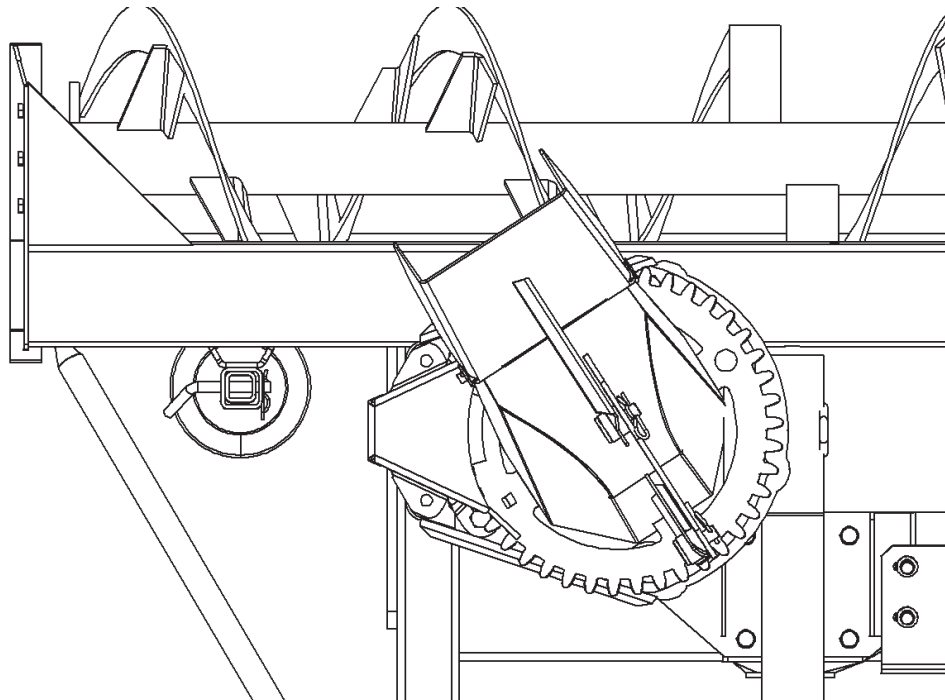

Chute Stop

The Chute Stop is standard on all Meteor Snowblowers.

It prevents the chute from being rotated straight back to the operator.

It prevents the Hydraulic hoses (*if used*) from getting wound around the chute.

On the smaller blowers with electric deflector actuator th Chute Stop prevents the wires from getting wound up.

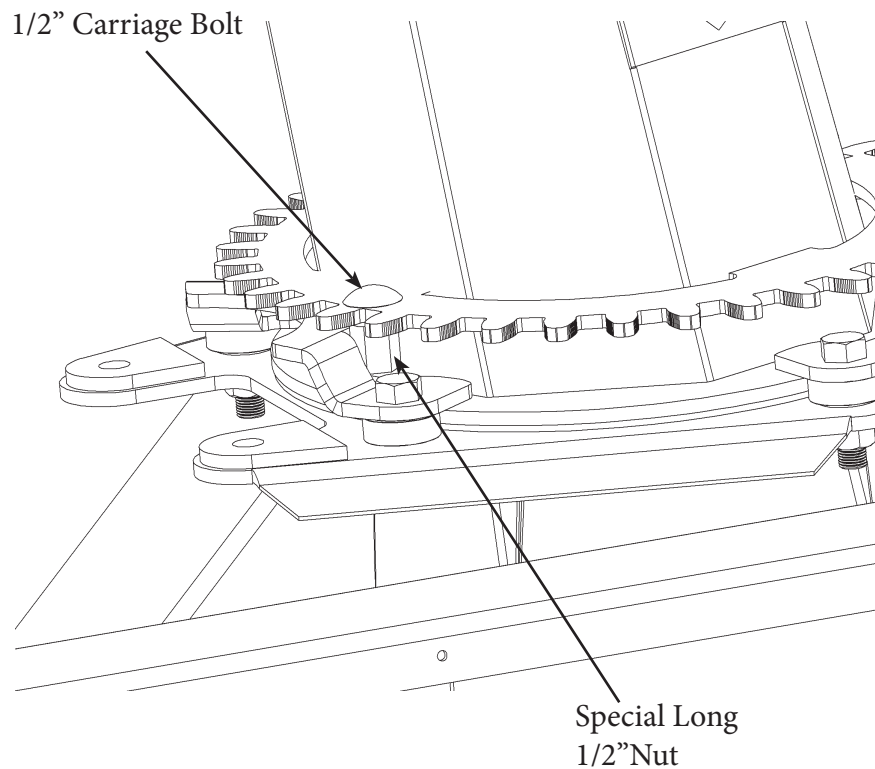

1/2x1 1/4 Carriage Bolt "OL"

1/2 Lockwasher "OL"

1/2 Long Nut Part No 519-511710

"OL" Obtain Locally

87-97 Meteor Snowblower Parts

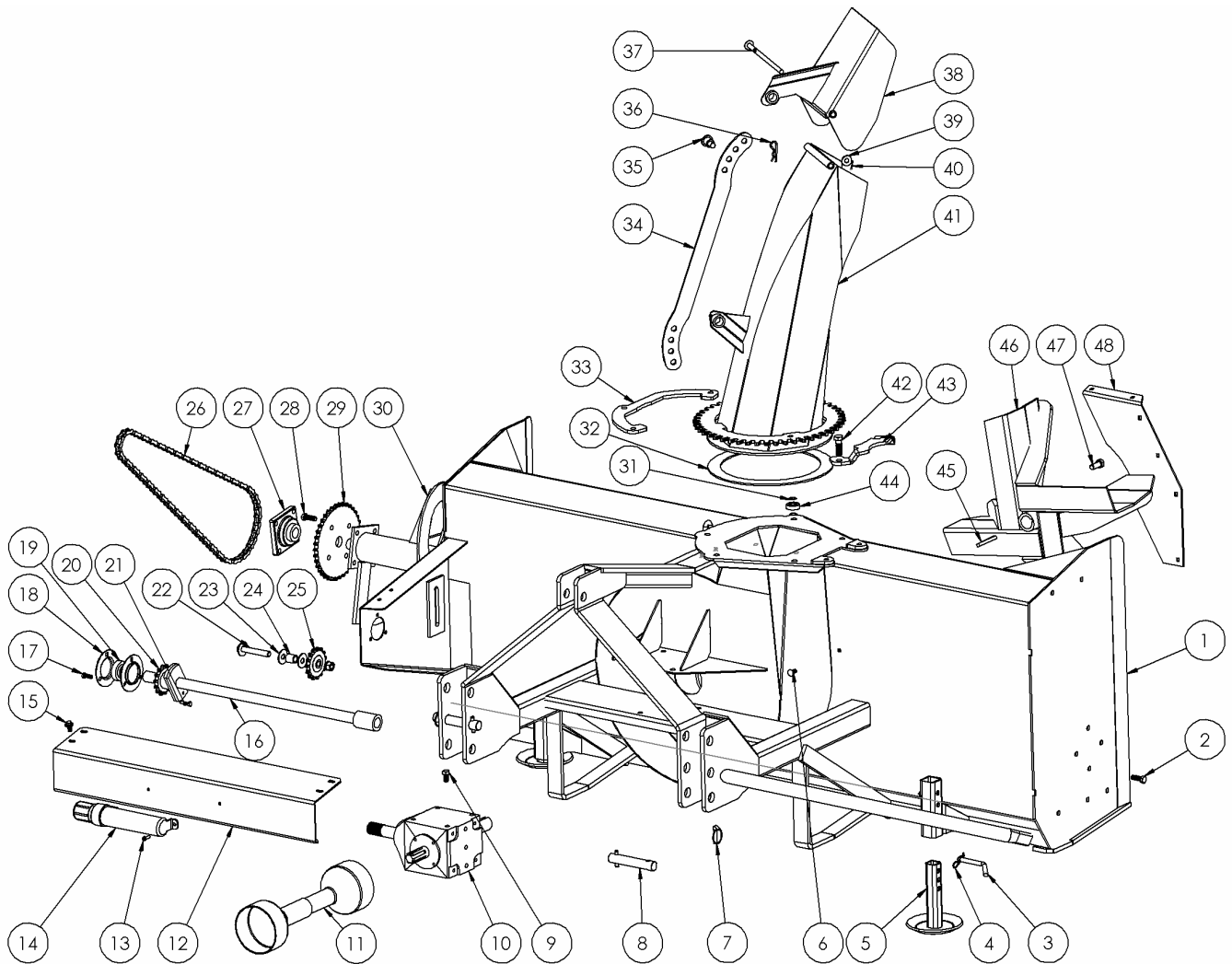

Item #	87 Part #	97 Part #	Description	Qty
1	23903	23904	Main Body	1
2	OL	OL	Bolt 1/2x1 1/2 c/w lw, n	8
3	OL	OL	1/2" Bent Pin	2
4	OL	OL	1/8" Hair Pin	2
5	21569	21569	Skid Shoe	2
6	OL	OL	Carriage Bolt 3/8x1 c/w ln	6
7	OL	OL	Lynch Pin	2
8	519-8720965	519-8720965	Hitch Pin	2
9	OL	OL	Bolt 1/2x1 c/w lw	8
10	519-871186	519-871186	Gearbox	1
11	519-871187	519-871187	PTO Assembly	1
12	31445	31344	Cross Shaft Shield	1
13	OL	OL	RH 1/4x1 Screw c/w ln	2
14	DJA70111	DJA70111	Operator Manual Tube	1
15	OL	OL	Bolt 3/8x1 c/w fw, lw	4
16	519-871184	519-971184	Cross Shaft (auger drive)	1

Item #	87 Part #	97 Part #	Description	Qty
17	OL	OL	Bolt 3/8x1 c/w lw, n	3
18	519-871174	519-871174	Flangette	2
19	519-871175	519-871175	Bearing	1
20	519-873025	519-873025	Shear Sprocket	1
21	OL	OL	Shear Bolt 5/16x1 1/4 #2 c/w ln	1
22	OL	OL	Bolt 5/8x4 c/w lw, n	1
23	OL	OL	5/8" Flatwasher	3
24	31348	31348	Idler Spacer	1
25	519-872029	519-872029	Idler Sprocket	1
26	519-872026	519-872026	Auger Drive Chain #60 x71 1/4" + Half Link + Connector Link	1
27	519-871169	519-871169	Auger Bearing	2
28	OL	OL	Bolt 1/2x1 1/2 c/w lw, n	4
29	519-871165	519-871165	Auger Sprocket	1
30	519-871164	519-971164	Auger	1
31	519-871702	519-871702	5/8" Wave Washer (thin)	10
32	519-871161	519-871161	Anti Friction Ring	1
33	10724	10724	3 Hole Chute Clamp	1
34	10701	10701	Deflector Adjuster Bar	1
35	21773	21773	Adjuster Bar Pin	2
36	OL	OL	5/32 Hair Pin	2
37	20897	20897	Deflector Hinge Pin	1
38	10707	10707	Chute Deflector	1
39	OL	OL	1/2" Flatwasher	1
40	OL	OL	1/8x1 Cotter Pin	1
41	10703	10703	Chute	1
42	OL	OL	Bolt 5/5 x 2 c/w lw, n	5
43	10725	10725	2 Hole Chute Clamp	1
44	519-870711	519-870711	Bearing	5
45	519-871062	519-871062	Fan Key 3/8 sq x 3 5/8	1
46	519-87115208	519-87115208	Fan	1
47	OL	OL	Bolt 5/8x1 1/2 c/w lw	1
48	20907	20907	Fan Plate	1

Notes

c/w - complete with
OL -- Obtain Locally
fw -- Flatwasher
lw -- Lockwasher
ln -- Locknut
n- Nut

87-97 Meteor Chute Rotator Manual Chute Rotator

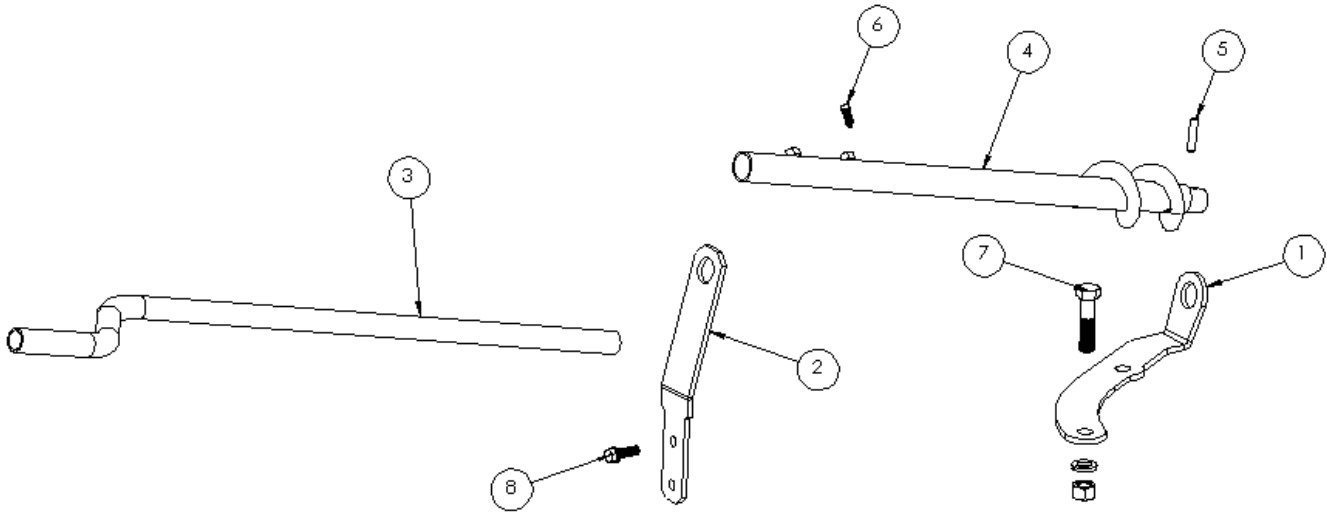

2010	Manual Rotator		
Item No	Description	Part No	Req
1	Crank Tail Bracket	519-87719109	1
2	Upper Hand Crank Bracket	519-87109009	1
3	Crank	519-68109109	
4	Crank Worm	519-68719209	1
5	5/16x1 1/2 Spring Pin	OL	1
6	5/16x3/4 sq h Setscrew	OL	2
7	5/8-11x2 1/2 Bolt c/w ln	OL	2
8	3/8x1 1/4 Bolt c/w n, lw	OL	2

Meteor Hydraulic Chute Rotator Parts

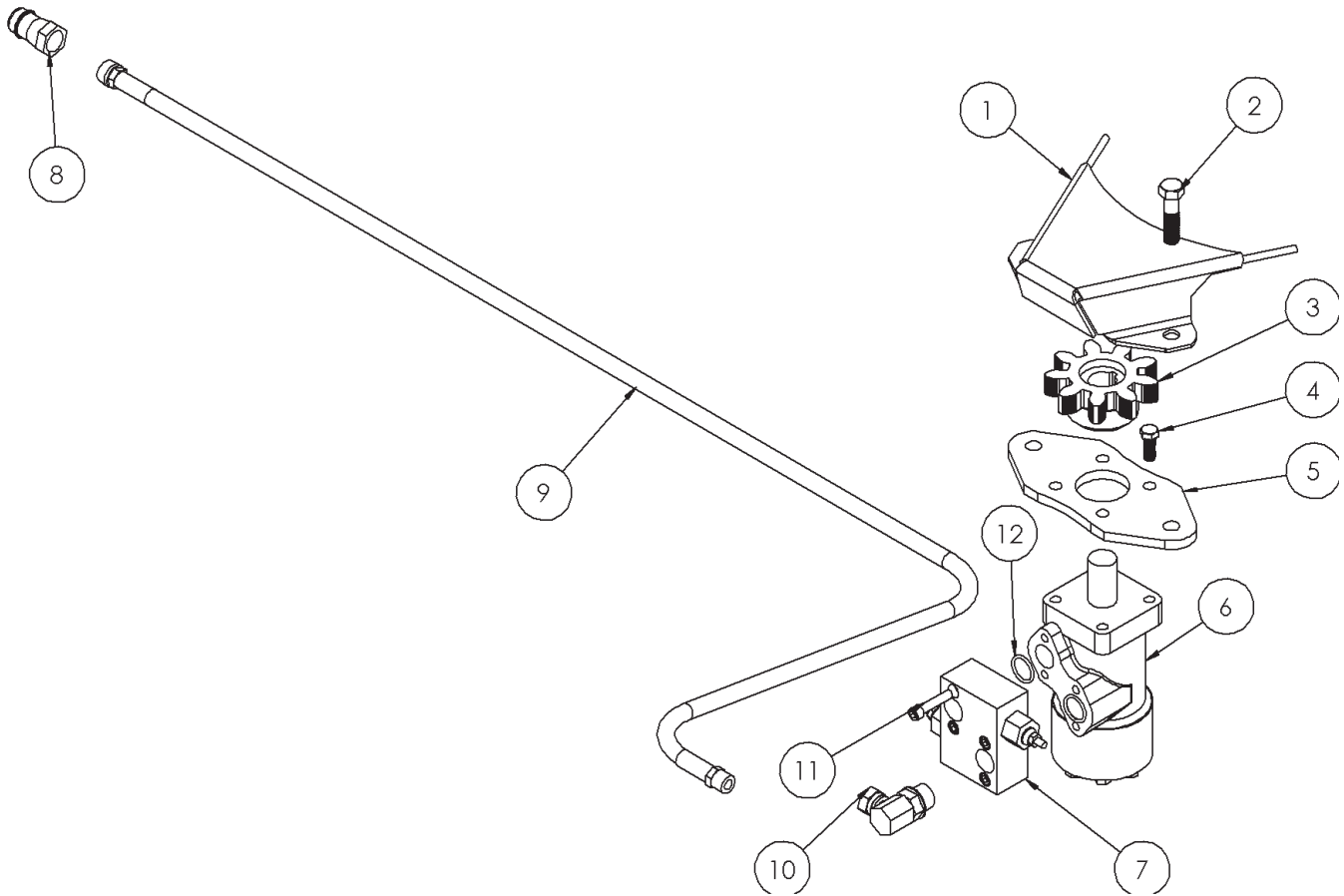

Item #	Part #	Description	Qty
1	23931	Shield	1
2	Bolt 1/2-20x2 c/w lw, n	OL*	2
3	519-511706	Small Gear	1
4	Bolt 3/8x1 c/w lw	OL*	4
5	519-511703	Motor Bracket	1
6	519-511704	Motor	1
7	519-511705	Crossover Relief Valve	1
8	S71-4	Tractor Adapter	2
9	23895	Hydraulic Hose	2
10	519-9515-10-6	Hydraulic Elbow	2
11	Socket Head Cap Screw 5/16x1 1/2	OL*	4

Note*

OL -- Obtain Locally

**75 – 87 – 87D - 97 Meteor Snowblower
Main Gearbox**

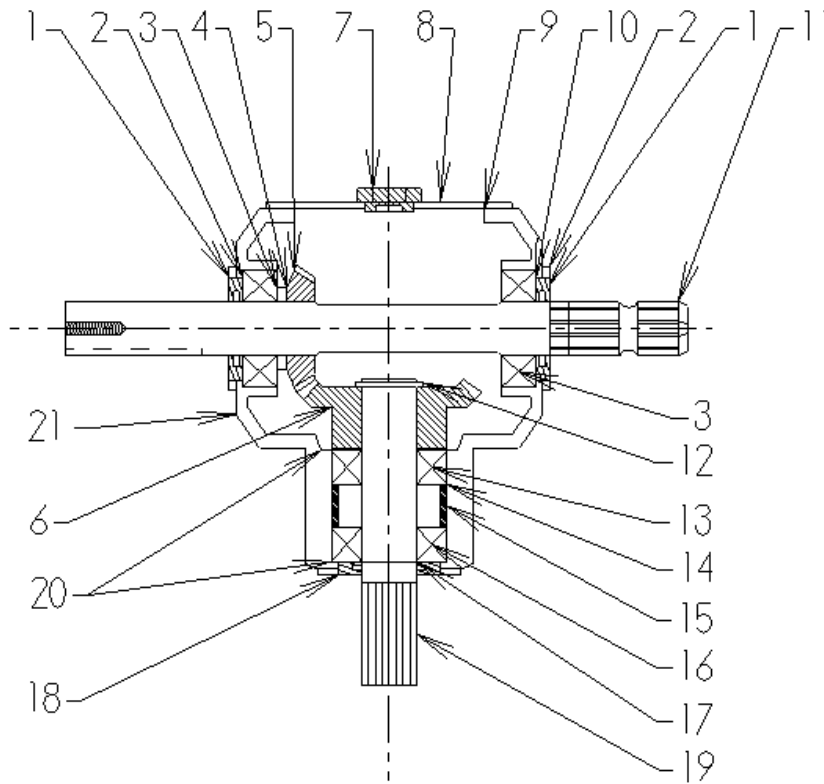

T 27D Gearbox			
Item	Description	Part #	Req
1	Double Lip Seal 40x80x12	519-87100748	2
2	Snap Ring	519-85200030	2
3	Bearing 30208	519-80900024	2
4	Shim 515	519-02447500	1
5	Gear Z18 M6.15	519-01325002	1
6	Gear Z18 M6.15	519-02675000	1
7	Plug	519-86500006	2
8	Cover	519-02671300	1
9	Bolt M10 x 14	519-81101031	4
10	Shim 79.7	519-01107500	1
11	Shaft (Thru)	519-02674221	1
12	Snap Ring 40 UN17435	519-85100029	1
13	Bearing 30207	519-80900026	1
14	Snap Ring 72 17437	519-85200131	1
15	Spacer	519-02677100	1
16	Bearing 6207	519-80100025	1
17	Snap Ring UN17435	519-85100005	1
18	Double Lip Seal 35x72x10	519-87100152	1
19	Shaft	519-02672000	1
20	Shim 48.0	519-02597500	2
21	Casing	519-02670301	1

Comer T50 PTO

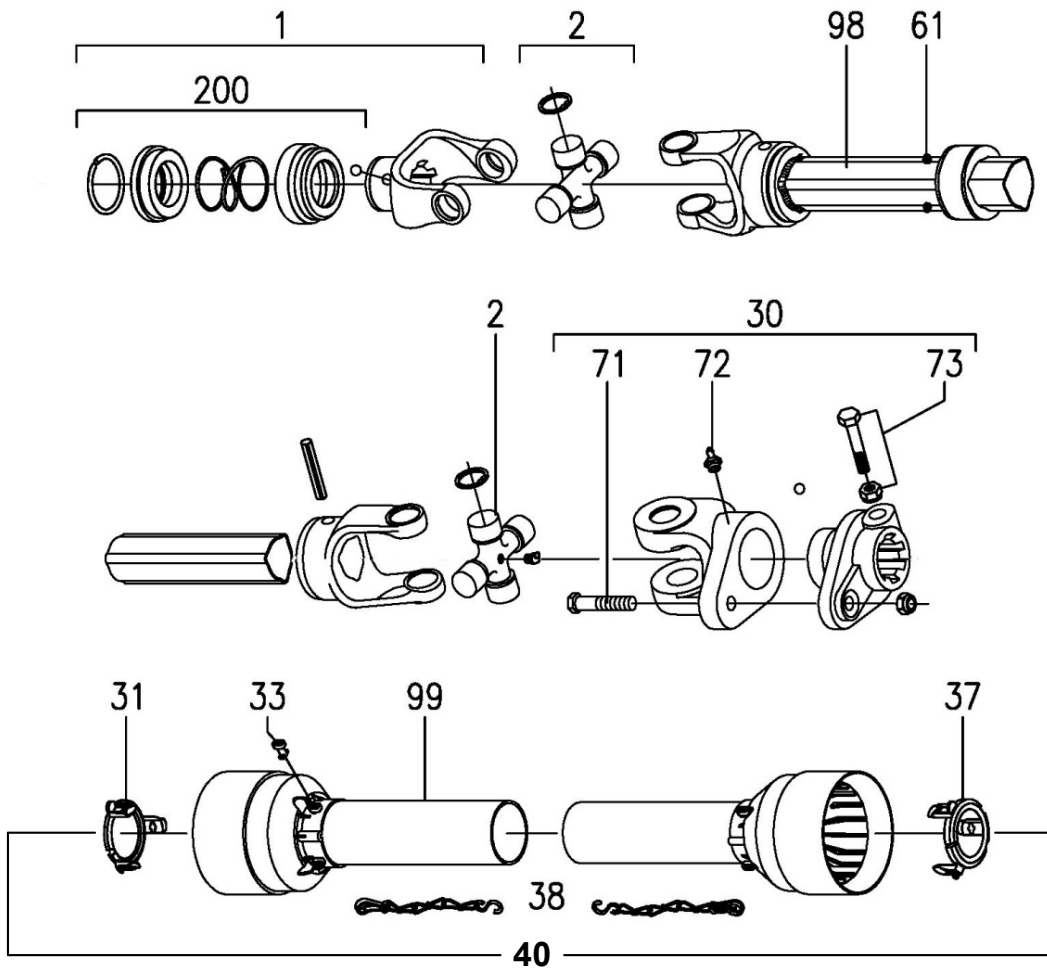

Item #	Description	Part#	Req
1	Complete Collar Yoke	141.025.363.1	1
2	Cross Journal Assy	180.015.130	2
30	Complete Shear Yoke	143.250.016.1	1
31	Guard Retaining Collar for Outer Tube	8180.015.288	1
33	Special Plastic Bolt	8180.014.240	6
37	Guard Retaining Collar of Inner Tube	8180.015.289	11
38	Safety Chain	180.016.025	2
40	Complete Guard with Instruction Manual	142.250.372.7521	1
61	Special Grease Nipple	8180.012.418	3
71	Bolt & Nut M10x55 cl. 8.8	165.000.511	1
72	Grease Fitting	190.000.020	1
73	Bolt & Nut M12x1.25x70 cl. 8.8	165.000.525	2
200	Collar Kit for 1 3/8" Yoke	165.000.628	1
	Danger Label for Outer Tube	190.000.216	1
	Danger Label for Outer Guard Tube	190.000.215	1
	PTO Instruction Manual	190.000.371	1

PTO Installation Instructions for Snowblower

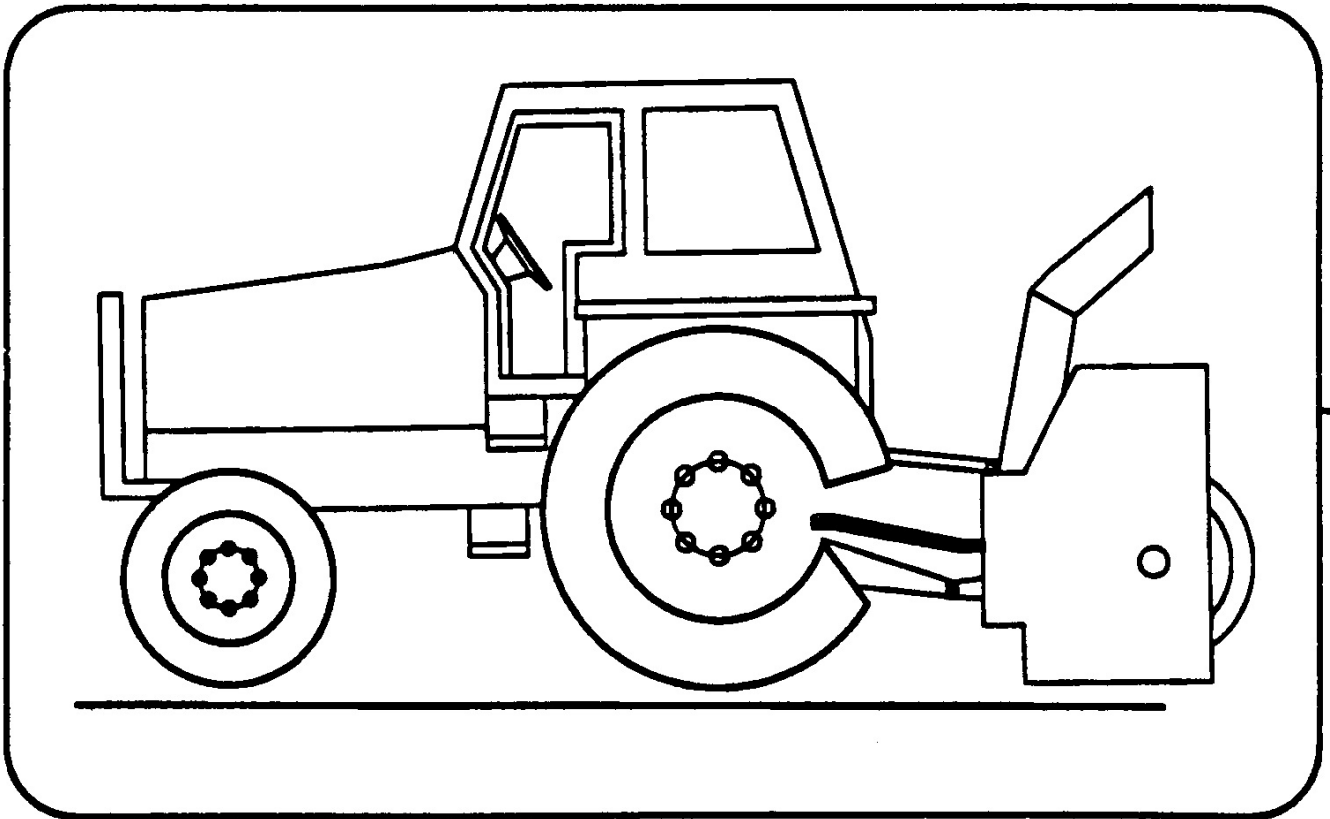

PTO Installation Instructions for Snowblower For Better PTO Shaft and Gearbox Operation

A proper initial installation will give you years of satisfactory service on your equipment. Please read carefully, following instructions which have been specially made to help you and make you satisfied of your purchase.

Warning! Unfortunately, snowblowers will be faced with forgotten or hidden objects under the snow, such as: chain, tires, stones, pieces of wood, etc. In spite of all our efforts, machines are not built to resist all those conditions.

Danger: Too big tractors

It is dangerous to use a that is too big or too powerful. The tractor will always be able to overload the blower, even if the machine is already at maximum capacity. Tractor being very high, too large angles at PTO universal joints will result, and the life of the universal joints will be shortened dramatically.

P T O Shaft angles

PTO shafts are made to transmit power with angle at universal joints. However these angles should be kept to a minimum. Larger angles shorten the life of PTO. Take for example a snowblower sold for a tractor horse-power of 60-75 HP which would be attached to a 60HP tractor operating at maximum capacity of (60HP continuous).

HP	PTO angles	Estimated life in hours
60@540 RPM	5°	450 hours
	10°	195 hours
	15°	90 hours
	20°	40 hours
	25°	20 hours

How to determine PTO angle

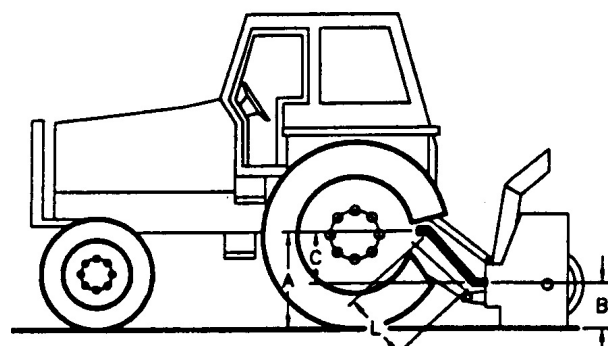

A =PTO height at tractor

B= PTO height at blower

C= A-B

L = Cross center distance in working position

- 1) Lower blower on ground
 - 2) Measure A,B and L
 - 3) Subtract B of A (A-B=C)
 - 4) Divide L by C (L/C=F)
- 5) Compare F Factor in the table below to find PTO angle. (Interpolate if necessary)

F Factor	Angle
6	10°
3.75	15°
2.75	20°
2.15	25°
1.75	30°

Previous examples clearly demonstrate that universal joint angle is directly related with life of PTO. In order to reduce angle, it is necessary to increase the angle between snowblower and tractor.

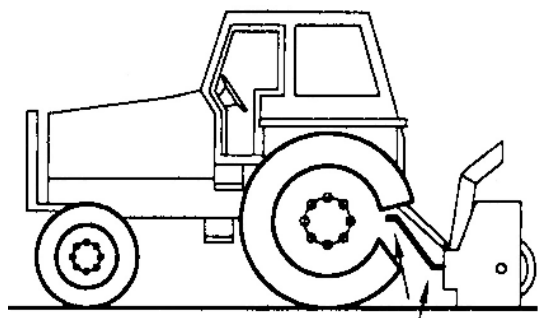

**Too Large Angles at PTO Joints
To Avoid**

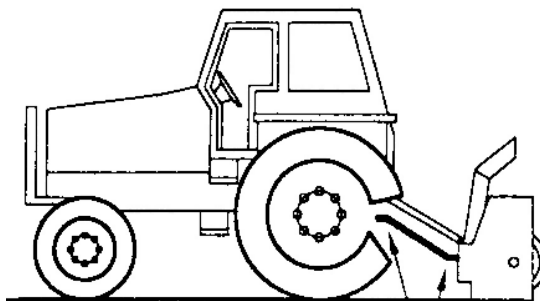

**Reasonable Angles at PTO Joints
Acceptable**

If it is impossible to increase the distance between snowblower and tractor, in order to maintain a reasonable angle at the PTO, it is recommended to use a larger size PTO that is a greater capacity PTO. (please refer to your dealer for more details).

For snowblowers of 100HP, an additional gearbox is also available that can be mounted on the existing snowblower gearbox, which increases the input shaft height, reducing the angle at PTO joints. This Gearbox has an input speed of 1000RPM which greatly increases PTO capacity.

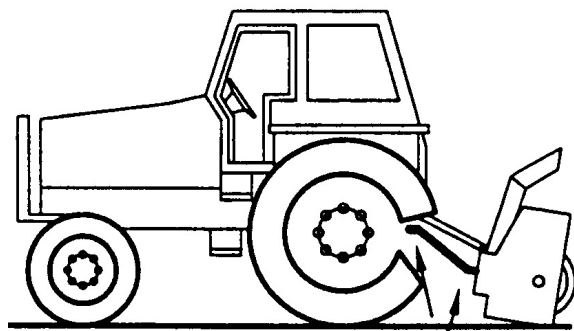

**Non-Equal Angles at PTO Joints
To Avoid**

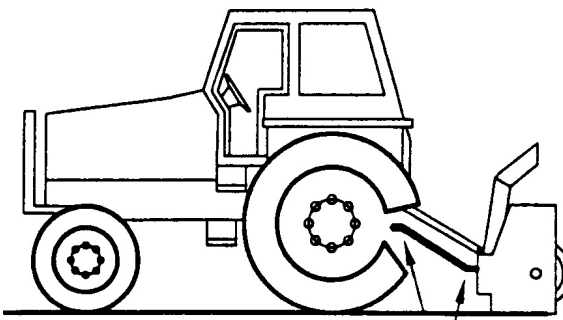

**Equal Angles At PTO Joints
Recommended**

Angles at each end of PTO

A popular habit is to change snowblower angle in order to obtain a better scraping effect. This practice can become harmful to the PTO if the angle is unequal at each end, There will be fan speed variation (as the fan speed up and slow down twice per revolution) as well as a drastic increase of loading on the cross and bearings. **To avoid** it is recommended to keep tractor PTO and snowblower input shaft always parallel.

Shear Bolts

Shear bolts are built to break under shock loads on the fan or auger. However under certain circumstances this security is not adequate. Example: a sudden high impact shock on the fan may, in some cases break the fan shaft without breaking the shear bolt.

If the shear bolt breaks, make sure to always replace it with the same grade of category bolt (grade 5 for PTO series **20-40-50-60**, and grade 8 for PTO series **80**) it is necessary to always maintain this bolt very tight in order to keep the efficiency of the shearing mechanism.

Warning: The gearbox shafts are made with special alloy steel. However they are case hardened to increase capacity to shock load. These shafts cannot be broken under normal loads. However undesirable objects may enter the fan and either bend or break the gearbox shaft. It is understood that the gearbox cannot be built to resist every possible overload and consequently, gearbox fan shafts will not be replaced under warranty. Therefore the user of the snowblower must be very careful.

Maximum length of PTO shaft

Warning: Telescopic tubes of PTO should overlap a minimum length to meet ideal conditions for transmitting power.

Following table could be used as a guide to find maximum permissible length of PTO.

PTO Description	Over-all length Closed	Over-all length Opened Max	Telescopic tube overlap
T20-056P	29 3/4"	41"	5"
T40-056P	30 1/2"	40 1/2"	6"
T50-071P	36 1/2"	51 1/4"	7"
T60-071P	37 3/4"	51 1/4"	7"
T80-066P	36"	47 1/4"	7"
T80-076P	40 1/2"	53"	8"
T90-071P	39"	51"	8"





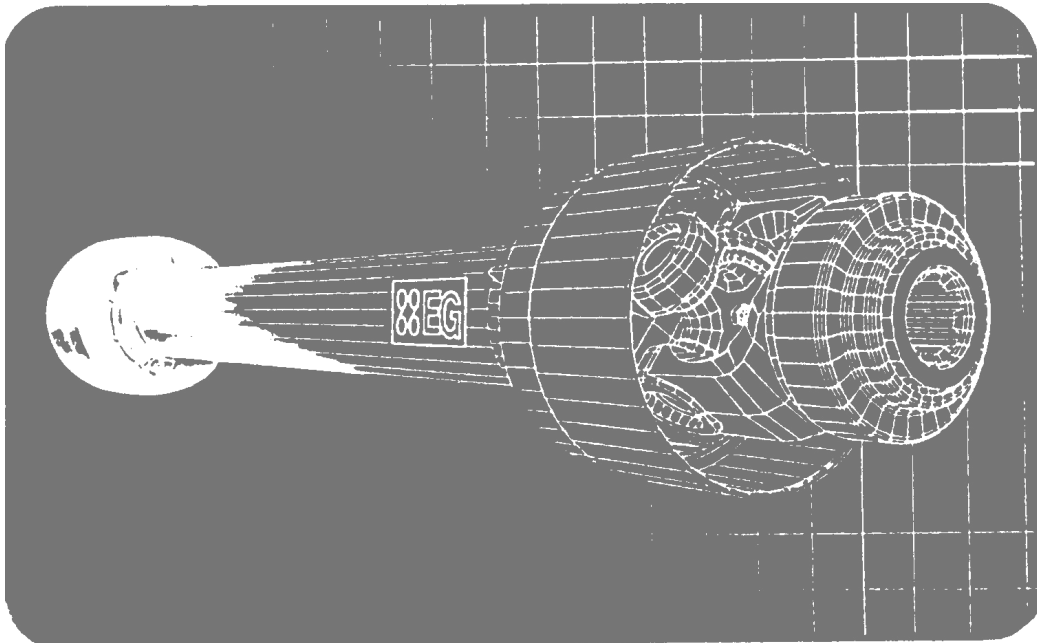

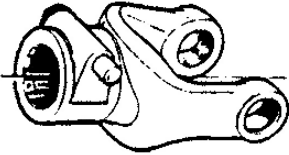
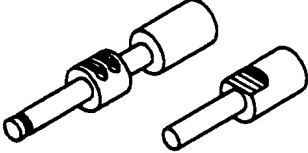
Effective PTO Drive Shaft Maintenance



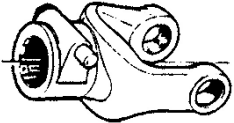

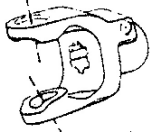
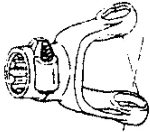

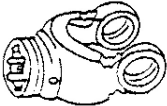
	Avoidable Damage	Possible Causes	Corrective Actions
Quick-disconnect yoke 	Quick-disconnect pin tight or completely seized Quick-disconnect pin damaged (broken or bent) Quick-disconnect pin damaged in locking position 	Quick-disconnect pin dirty (insufficient maintenance) Quick-disconnect pin defective (forced into place, incorrect handling). Excessive shaft length Axial load too high	Clean, oil and follow service instruction Replace Quick-disconnect pin Shorten shaft length (cut both telescopic tubes as well as shield, remove burrs) Replace Quick-disconnect pin Clean and grease telescopic tubes. Replace both tubes if necessary

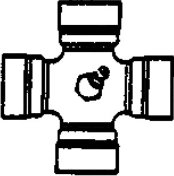
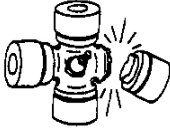
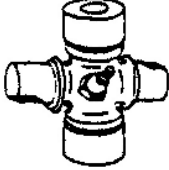
Note: newer PTO shafts may have a locking collar. (Damages Causes and corrective actions will still be similar.)



	Avoidable Damage	Possible Causes	Corrective Actions
Yoke  	Deformed Yoke  	Excessive shaft length Axial load too high Excessive working angle and torque	Shorten shaft length (cut both telescopic tubes as well as shield, remove burrs) Replace defective yokes Clean and grease telescopic tubes. Replace both tubes if necessary Replace defective yokes Verify compatibility between shaft and working conditions (torque vs. angle) Disengage tractor PTO during lifting or lowering the implement. Change to a larger PTO size
	Distorted Yoke 	Overload caused by high starting and peak torque	Engage PTO more carefully Use appropriate safety device Replace defective yoke
	Worn or pounded Yoke 	Excessive working angle	Avoid excessive angle Replace defective yokes

	Avoidable Damages	Possible Causes	Corrective Actions
Cross Kit 	Cross Arms broken 	Extreme torque peak or shock load Axial loads too large	Use appropriate safety device Change to a larger PTO size Shorten PTO shaft Replace defective cross bearings
	Bearing caps turning in their cross journal Overheated bearing caps	Excessive continuous torque and/or excessive working angle Inadequate greasing	Verify compatibility between shaft and working conditions Carefully follow greasing instructions Replace defective cross bearings
	Accelerated wear of cross kit 	Excessive continuous torque and/or excessive working angle Inadequate greasing	Verify compatibility between shaft and working conditions Carefully follow greasing instructions Replace defective cross bearings

Note: Cross bearings must be greased every 8 working hours

	Avoidable Damages	Possible Causes	Corrective Actions
Telescopic tube 	Telescopic tube failure or twisting 	Excessive torque or shock load Short tube engagement (overlap)	Use appropriate safety device Change to a larger PTO size Replace the PTO drive shaft with one of adequate length Replace defective tubes
	Accelerated wear of telescopic tubes 	 Extreme load when sliding Short tube engagement Inadequate greasing Conditions (sand etc)	Change to a PTO with coated tube Replace the PTO drive shaft with one having proper length Carefully follow greasing instructions Replace defective tubes

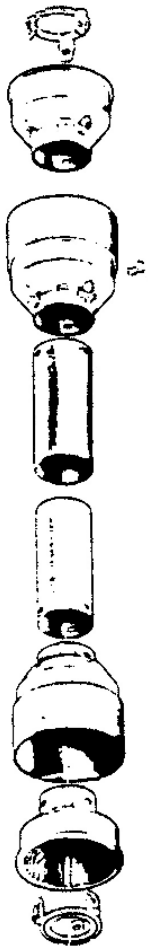
Note: Telescopic tubes must be cleaned and greased every 16 working hours

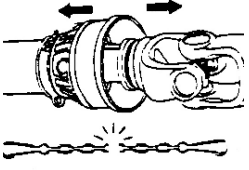
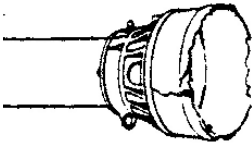
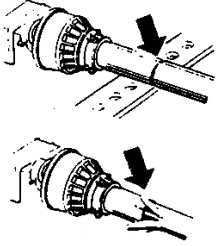
	Avoidable Damages	Possible Causes	Corrective Actions
Shield 	Excessive wear of shield bearings 	Insufficient lubrication Incorrect chain mounting Shield interfering with implement	Follow lubrication instructions Mount chain to allow maximum angularity Avoid shield contact with machine or tractor Replace shield bearings
	Chain failure 	Shield interfering with implement Incorrect chain mounting	Avoid shield contact with machine or tractor Mount chain to allow for maximum angularity Replace defective parts
	Guard cone damaged 	Guard cone in contact with implement or tractor Excessive angularity	Eliminate interference between guard cone and any part of implement or tractor Avoid excessive angles Replace damaged guard cone
	Guard tubes damaged (deformed and split at one side) 	Guards are in contact with tractor or implement Guard tube overlap too short or no overlap with PTO tube extended	Eliminate interference between guard cone and any part of implement or tractor Replace damaged tubes Adjust guard tube length with longer tubes

Note: Shield bearing must be greased every 8 working hours

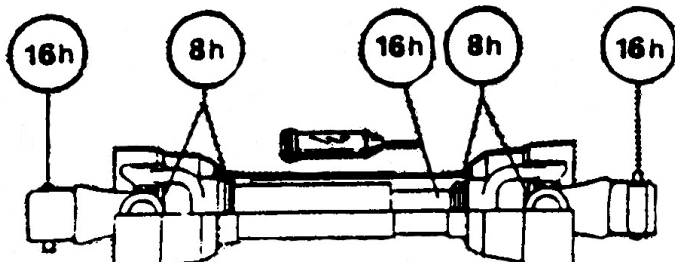

Bolt Torque

As used on this equipment

Bolt torque table shown below gives torque values for the various bolts used. This chart is for non-lubricated threads. Replace with the same strength bolt.

Torque Specifications. Torque values are identified by their head markings

Diameter	SAE 2		SAE 5		SAE 8	
	Lb-ft	Nm	Lb-ft	Nm	Lb-ft	Nm
1/4	6	(8)	9	(12)	12	(17)
5/16	10	(13)	19	(25)	27	(36)
3/8	20	(27)	33	(45)	45	(63)
7/16	30	(41)	53	(72)	75	(100)
1/2	45	(61)	80	(110)	115	(155)
5/8	95	(128)	160	(215)	220	(305)
3/4	165	(225)	290	(390)	400	(540)
1	225	(345)	630	(850)	970	(1320)

Allen head cap screws are similar to SAE 8 quality.

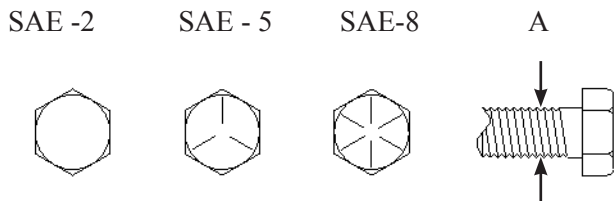

These torques are for a reference only. Not all these sizes and grades are necessarily used in this machine. Bolts that are used as a pivot or hinge have to be used with a locknut, therefore only tighten enough to secure the bolt and still allowing the part to rotate freely.

87-97 Meteor Snowblower

Maintenance

- PTO Shearbolt – M10x50 - - 8.8
- Auger Shearbolt – 5/16 x 1 1/4” Gr #2
- Auger Drive Chain Tightener – tighten chain allowing 1/4” sag in the bottom span of chain (between drive and driven sprocket).

Lubrication

- Gearbox- check oil level every **50** hours. Fill to oil level plug (middle of gearbox) with SAE 90 gear oil. SAE 80W90 gear oil may also be used.
- Auger and Shear Sprocket Bearing – grease sparingly every **50** hours. (By using too much grease you will push the seals off the bearing).
- PTO Shaft – grease every **10** hours. Pull apart and apply grease to the sliding members. Grease the yoke bearings at this time as well.
- Auger Chain – apply oil on a regular basis especially after using the snowblower.

Storing the Meteor Snowblower in the off season

- At the end of the season lubricate the Bearings, PTO shaft and Auger chain before storing it.

Notes

Part numbers – Abbreviations

O/L – obtain locally

N --- Nut

LW- Lockwasher

- All fasteners are Grade #2 unless otherwise specified.
- Customer supplies hydraulic cylinders.